

**ATTENTION! IMPORTANT:**

Use correct tightening torque on bolts of shaft clamp bushing and gearbox.

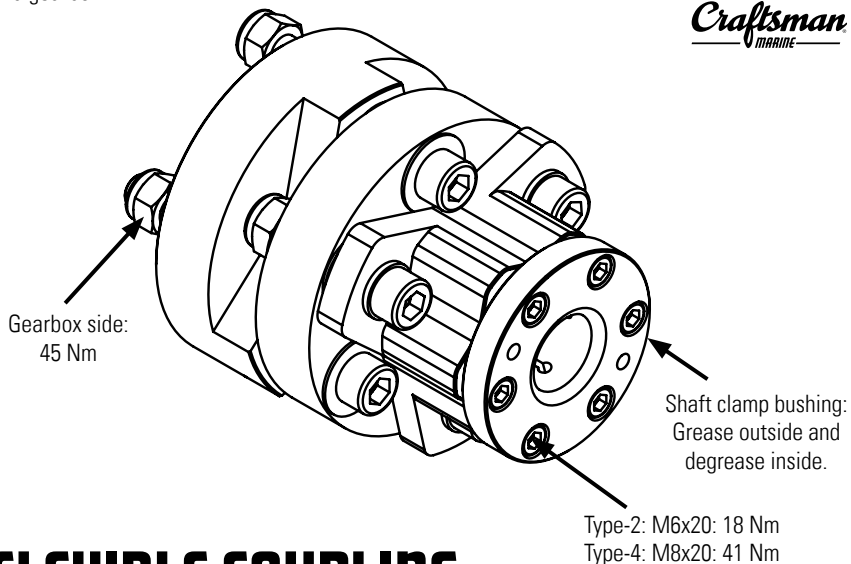

*Craftsman*  
MARINE



# FLEXIBLE COUPLING GYROFLEX

INSTALLATION/  
INSTRUCTIONS

TYPE-2: **AI.030.22025**    TYPE-4: **AI.030.24030**  
**AI.030.22030**                **AI.030.24035**

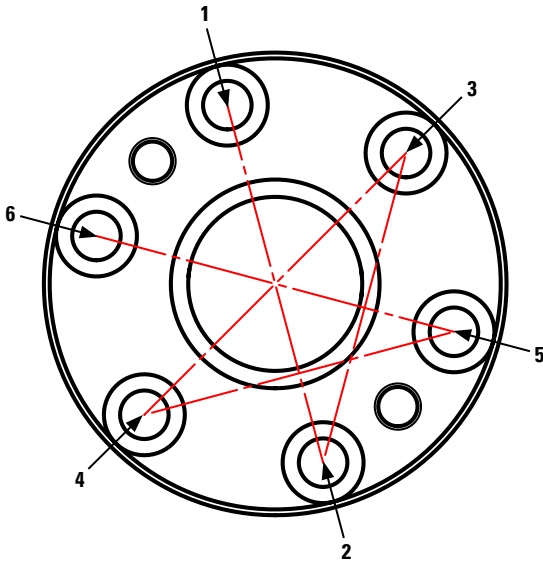

It is recommended to tighten the bolts equally by diagonal sequence as indicated in the drawing;

1. Tighten bolts to around 50% of the specified torque
2. Tighten bolts to around 75% of the specified torque
3. Tighten bolts to 100% of the specified torque